

B28

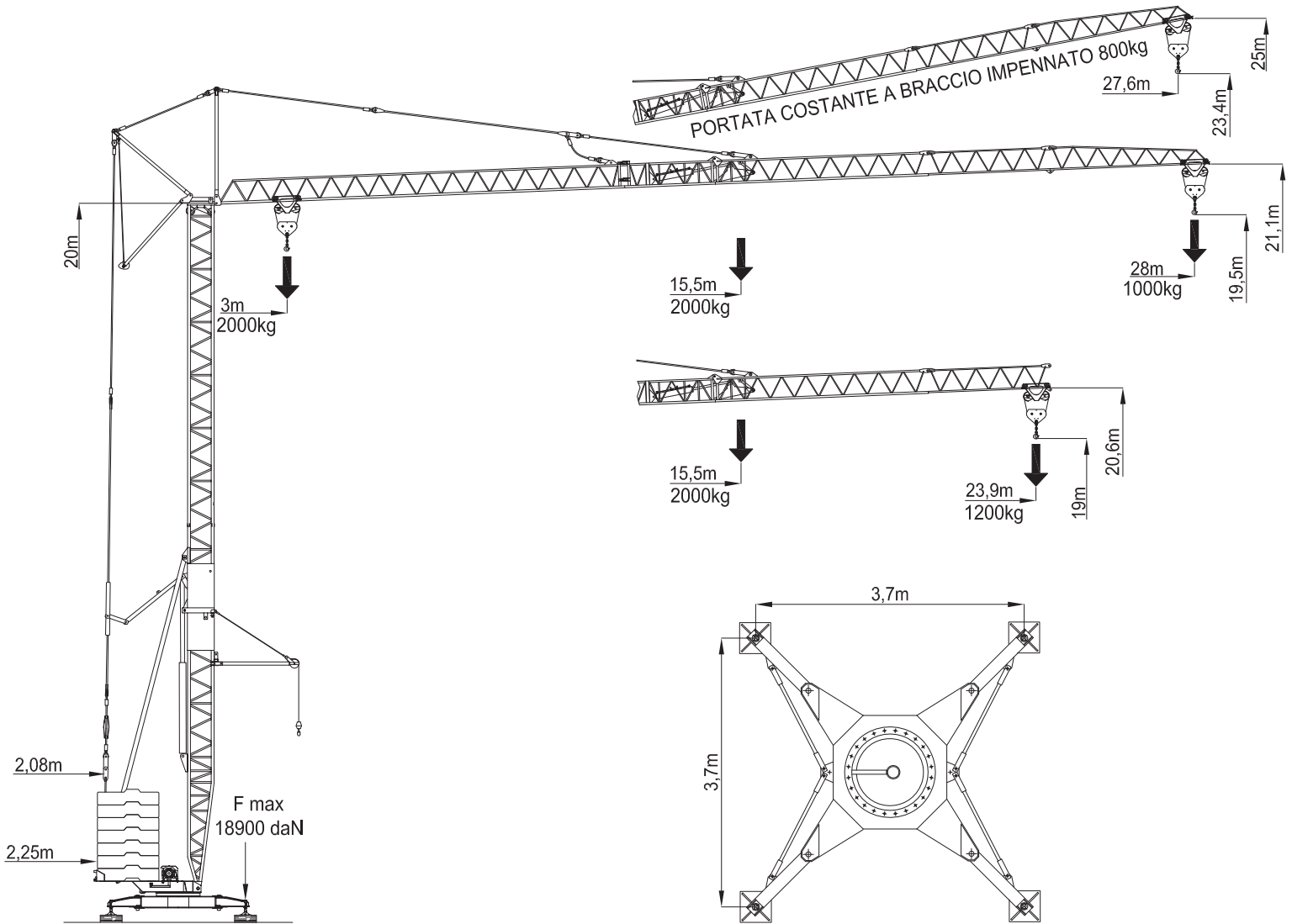

- Gru automontante
- Self erecting cranes
- Grúa automontante
- Grue auto montante



CE FEM A4

		400v/50hz 10kW			
		m/min	kg	kW	
Sollevamento Hoisting Levage Elevaciòn			5	2000kg	7,5
			17	2000kg	
			33	1000kg	
Traslazione Trolleying Distribution Distribuciòn			20	2000kg	2,2
			30	2000kg	
			40	1000kg	
Rotazione Slewing Orientation Orientaciòn			0,2 rpm	2000kg	2,2
			0,4 rpm		
			0,8 rpm		

Alimentazione Elettrica Main Supply Rèseau Alimentaciòn	400v/50hz – 10kW
Montaggio Erection Montage Montaje	400v/50hz – 3kW
Peso Gru Crane Weight Poids Grue Peso Grúa	10000 kg
Zavorra Ballast lest Lastre	18200 kg

B28

-  Montaggio
-  Erection
-  Montaje
-  Montage



Apertura aerea idraulica del braccio.
 Ripiegamento idraulico laterale del braccio per altezza gru in sagoma.
 Sterzo montato su ralla.
 Carro gommato con 8 ruote per traino.
 Tre velocità sollevamento con rampa di accelerazione e decelerazione pilotate da inverter.
 Tre velocità rotazione con rampa di accelerazione e decelerazione pilotate da inverter.
 Due velocità carrello pilotate da inverter.
 Finercorsa di rotazione.
 Stabilizzatore idraulico per auto livellamento.
 Zincatura: torre, braccio, tiranti, cuspidi, funi, perni.
 Falcone per auto zavorramento.
 Benna tronco conica.
 Impennaggio braccio con carrello traslante con portata costante kg.800.
 Cofano apparecchiatura elettrica in acciaio inox.
 Radiocomando manipolatore con visualizzazione del carico.
 Radiocomando pulsantiera di emergenza.
 Sistema di tele-assistenza.



Hydraulic air opening of the jib.
 Lateral hydraulic folding of jib for crane height in outline.
 Steering wheel fitted on fifth wheel.
 Tyred truck with 8 wheels for towing.
 Three lifting speeds controlled by inverter.
 Three rotation speeds with acceleration and deceleration ramps.
 Two speed trolley controlled by inverter.
 Rotation limit switch.
 Hydraulic stabiliser for self-levelling.
 Galvanising: tower, jibs, tie rods, struts, cables, pivots.
 Self-ballasting derrick.
 Conical bucket.
 Jib tail with traverse trolley with constant capacity 800 kg.
 Casing for electric equipment in stainless steel.
 Wireless joysticks keyboard with visualization of weight.
 Wireless push-button emergency keyboard.
 Tele-assistance system.



Despliegue hidráulico aéreo de la pluma.
 Repliegue hidráulico lateral de la pluma para altura de la grúa repliegada.
 Dirección montada sobre corona de giro.
 Chasis de 8 ruedas para remolque.
 Tres velocidades de elevación con rampa de aceleración y desaceleración controladas por inverter.
 Tres velocidades de giro con rampa de aceleración y desaceleración controladas por inverter.
 Dos velocidades de carrito con rampa de aceleración y desaceleración controladas por inverter.
 Limitadores de giro.
 Estabilizador hidráulico para autonivelación.
 Cincado: torre, plumas, tirantes, cúspides, cables, pernos.
 Plumin para autocontrapeso.
 Cubilotes.
 Izado pluma con carro de traslación de carga constante de 800 kg.
 Armario equipo eléctrico en acero inoxidable.
 Radiocontrol con manipulador con visualización peso.
 Radiocontrol con botones de emergencia.
 Sistema de tele-asistencia.



Dépliage hydraulique aérien de la flèche.
 Repliage hydraulique latéral de la flèche pour hauteur de la grue dans le gabarit.
 Système d'orientation monté sur sellette d'attelage.
 Châssis mobile à 8 roues pour remorque.
 Trois vitesses de levage avec rampe d'accélération et de décélération commandées par inverseur.
 Trois vitesses de rotation avec rampe d'accélération et de décélération commandées par inverseur.
 Deux vitesses du chariot avec rampe d'accélération et de décélération commandées par inverseur.
 Butée de rotation.
 Vérin de stabilité hydraulique pour auto-nivelage.
 Zingage: tour, flèches, tirants, têtes, câbles, pivots.
 Chevalet d'auto-lestage.
 Benne à béton.
 Empennage de la flèche avec chariot translateur à capacité constante de 800 kg.
 Lest en plaques en béton armé.
 Capot en acier inoxydable pour appareillage électrique.
 Télécommande radio à manipulateur avec visualisation du poids.
 Télécommande avec boutons de urgence.
 Système de télé-assistance.

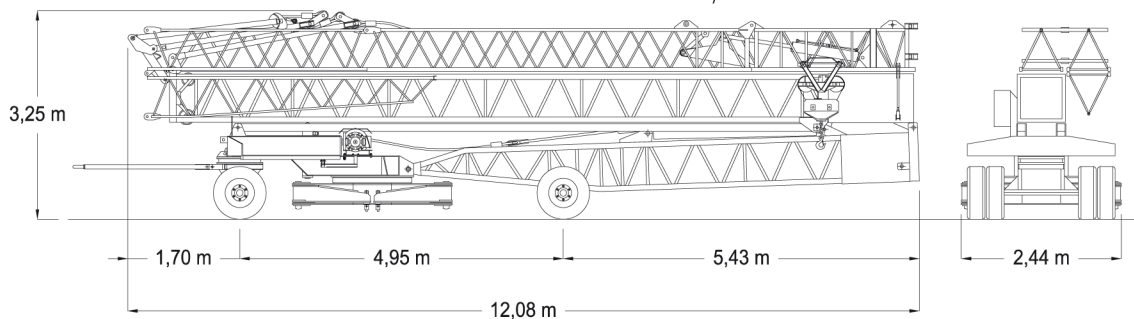
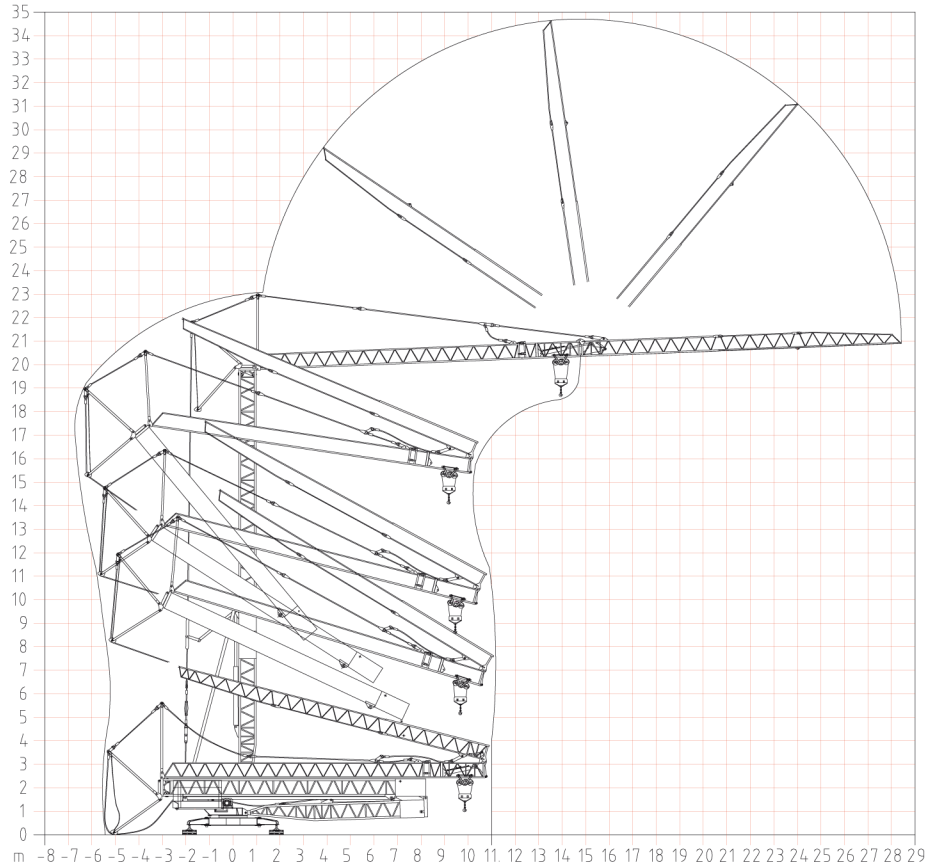

-  Trasporto
-  Transportation
-  Transporte
-  Transport

Rivenditore / Reseller / Minorista / Détaillant



Via Circonvallazione Est, 29
 46047 Porto Mantovano MN - ITALY
 Tel. +39 0376 1620500
 Fax +39 0376 397274
 www.grubenedini.it
 info@grubenedini.it